

Bucket fondo piano per impieghi pesanti (Tipo HD) Flat bottom bucket for heavy duty (HD type)

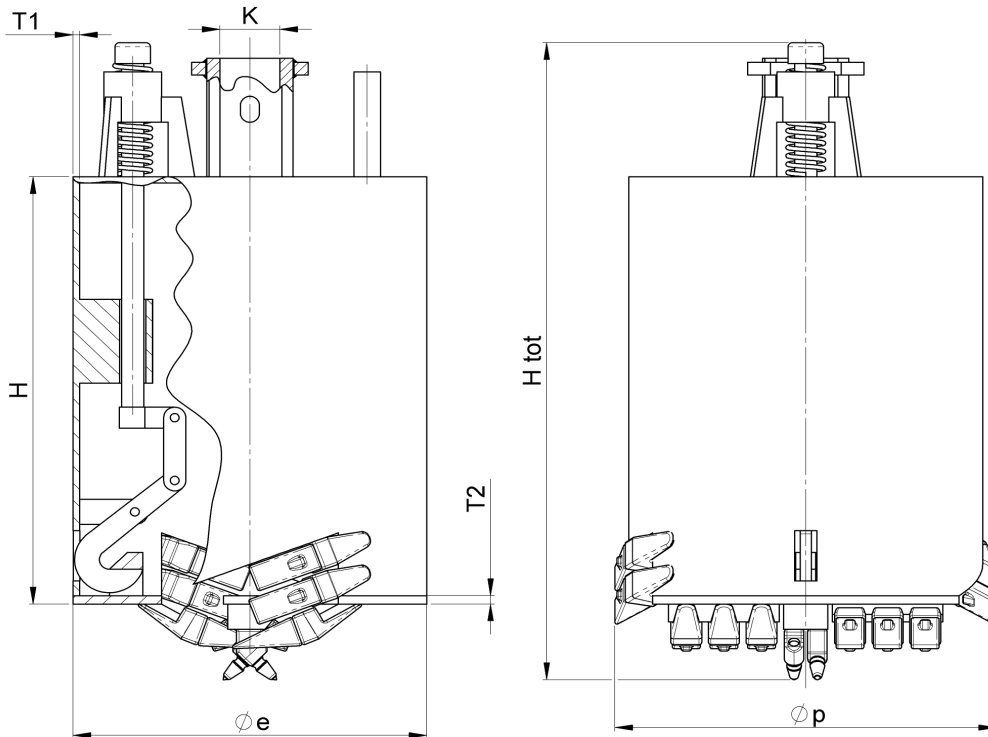

Diametro di perforazione	Diametro fusto	Spessore fusto	Spessore Fondo *	N° Denti		Altezza fusto	Altezza totale	Lato int. Attacco quadro	Codice
Drilling Diameter	Drum Diameter	Drum wall thick.	Bottom wall thick.*	Number of teeth		Drum Height	Total Height	Kelly Box dimension	Part Number
ϕp (mm)	ϕe (mm)	T1 (mm)	T2 (mm)*	TL 18	T 25	H (mm)	H tot (mm)	K (mm)	
400	310	20	40	6	-	1000	1600	130	BFP040-1-10L-4
						1500	2100	130	BFP040-1-15L-4
500	410	20	40	6	-	1000	1600	130	BFP050-1-10L-4
						1500	2100	130	BFP050-1-15L-4
600	510	20	40	8	-	1000	1600	130	BFP060-1-10L-4
								200	BFP060-2-10L-4
						1500	2100	130	BFP060-1-15L-4
								200	BFP060-2-15L-4
700	610	20	40	12	-	1000	1600	130	BFP070-1-10L-4
								200	BFP070-2-10L-4
						1500	2100	130	BFP070-1-15L-4
								200	BFP070-2-15L-4
800	710	20	40	14	-	1000	1600	130	BFP080-1-10L-4
								200	BFP080-2-10L-4
						1500	2100	130	BFP080-1-15L-4
								200	BFP080-2-15L-4
900	810	20	40	16	-	1000	1600	130	BFP090-1-10L-4
								200	BFP090-2-10L-4
						1500	2100	130	BFP090-1-15L-4
								200	BFP090-2-15L-4
1000	910	30	40	-	12	1000	1600	130	BFP100-1-30L-4
								200	BFP100-2-30L-4
						1500	2100	130	BFP100-1-35L-4
								200	BFP100-2-35L-4

Carandina migliora costantemente i propri prodotti riservandosi il diritto di apportare qualsiasi modifica senza preavviso. - Carandina s.r.l. continually improves its products reserving the right to modify data without warning.

Carandina produce utensili anche su specifiche del cliente - Carandina s.r.l. produces also drilling tools on customer's demand

* Su richiesta, si realizza il fondo in HARDOX 400 oppure acciaio T-1 - On demand, Carandina produces the bottom of the buckets in HARDOX 400 or T-1 steel

Diametro di perforazione	Diametro fusto	Spessore fusto	Spessore Fondo *	N° Denti		Altezza fusto	Altezza totale	Lato int. Attacco quadro	Codice
<i>Drilling Diameter</i>	<i>Drum Diameter</i>	<i>Drum wall thick.</i>	<i>Bottom wall thick.*</i>	Number of teeth		<i>Drum Height</i>	<i>Total Height</i>	<i>Kelly Box dimension</i>	<i>Part Number</i>
<i>Øp (mm)</i>	<i>Øe (mm)</i>	<i>T1 (mm)</i>	<i>T2 (mm)*</i>	<i>TL 18</i>	<i>T 25</i>	<i>H (mm)</i>	<i>H tot (mm)</i>	<i>K (mm)</i>	
1200	1110	30	40	-	16	1000	1600	130	BFP120-1-30L-4
								200	BFP120-2-30L-4
						1500	2100	130	BFP120-1-35L-4
								200	BFP120-2-35L-4
1400	1310	30	50	-	18	1000	1600	130	BFP140-1-30L-5
								200	BFP140-2-30L-5
						1500	2100	130	BFP140-1-35L-5
								200	BFP140-2-35L-5
1500	1410	30	50	-	18	1000	1600	130	BFP150-1-30L-5
								200	BFP150-2-30L-5
						1500	2100	130	BFP150-1-35L-5
								200	BFP150-2-35L-5
1800	1710	30	50	-	22	1000	1600	130	BFP180-1-30L-5
								200	BFP180-2-30L-5
						1500	2100	130	BFP180-1-35L-5
								200	BFP180-2-35L-5
2000	1910	30	50	-	24	1000	1600	130	BFP200-1-30L-5
								200	BFP200-2-30L-5
2500	2410	30	60	-	30	1000	1600	130	BFP250-1-30L-6
								200	BFP250-2-30L-6
2700	2610	30	60	-	32	1000	1600	130	BFP270-1-30L-6
								200	BFP270-2-30L-6
3000	2910	30	60	-	36	1000	1600	130	BFP300-1-30L-6
								200	BFP300-2-30L-6

Carandina migliora costantemente i propri prodotti riservandosi il diritto di apportare qualsiasi modifica senza preavviso.-Carandina s.r.l. continually improves its products reserving the right to modify data without warning.

Carandina produce utensili anche su specifiche del cliente - Carandina s.r.l. produces also drilling tools on customer's demand

*** Su richiesta, si realizza il fondo in HARDOX 400 oppure acciaio T-1 - On demand, Carandina produces the bottom of the buckets in HARDOX 400 or T-1 steel**